

6

5

4

3

2

1

NOTES UNLESS OTHERWISE SPECIFIED

- 1 MATERIAL: 6063-T6
- 2 FINISH: BARE
- 3 MAKE FROM: 40-4080 T SLOT EXTRUSION, LIGHTWEIGHT

DOCUMENT REVISION HISTORY			
REV.	DESCRIPTION	DATE	APPROVED
A	INITIAL RELEASE	10 APR 2022	A. BURKS

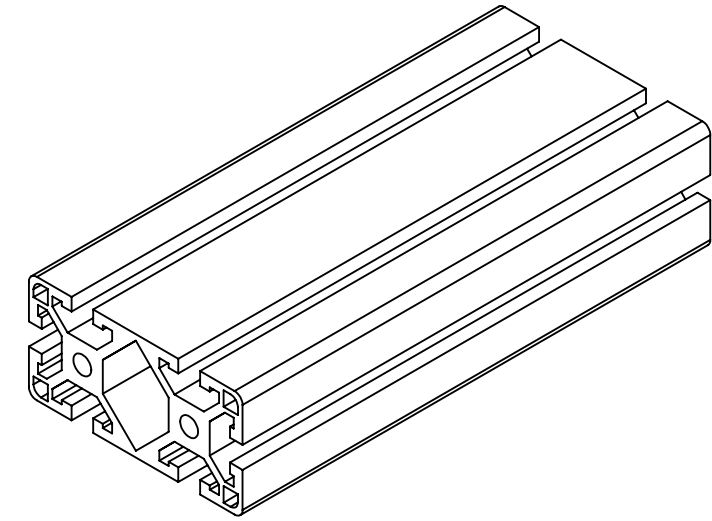
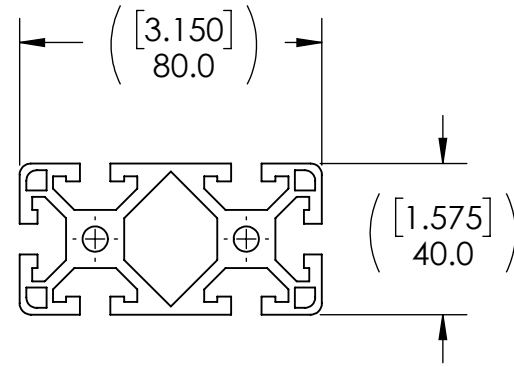
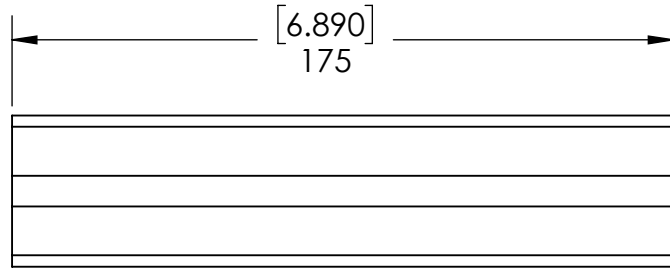

	NAME	DATE
DRAWN	A. BURKS	4/10/2022
CHECKED		
ANALYZED	A. BURKS	4/10/2022
APPROVED	A. BURKS	4/10/2022

BURKS BUILDS
www.burksbuilds.com

DRAWING TITLE
E-CHAIN MOUNT

THE DESIGN IS PROVIDED "AS IS", WITHOUT WARRANTY OF ANY KIND, EXPRESS OR IMPLIED, INCLUDING BUT NOT LIMITED TO THE WARRANTIES OF MERCHANTABILITY, FITNESS FOR A PARTICULAR PURPOSE AND NON-INFRINGEMENT. IN NO EVENT SHALL THE AUTHORS OR COPYRIGHT HOLDERS BE LIABLE FOR ANY CLAIM, DAMAGES OR OTHER LIABILITY, WHETHER IN AN ACTION OF CONTRACT, TORT OR OTHERWISE, ARISING FROM, OUT OF OR IN CONNECTION WITH THE DESIGN OR THE USE OR OTHER DEALINGS IN THE DESIGN.

UNLESS OTHERWISE SPECIFIED:
DIMENSIONS ARE IN MILLIMETERS
INTERPRET DRAWING PER ASME Y14.100
INTERPRET DIMENSIONS PER ASME Y14.5

TOLERANCES, UNLESS OTHERWISE SPECIFIED:
X ±2.0 X° ±1.0°
X.X ±0.5 X.X° ±0.2°
X.XX ±0.25

DRAWING ID CNCR-CAR-TSE-ECM	REV A
DO NOT SCALE DRAWING	THIRD ANGLE
SHEET 1 OF 1	

6

5

4

3

2

1

D

C

B

A

D

C

B

A