

6

5

4

3

2

1

NOTES UNLESS OTHERWISE SPECIFIED

- 1 MATERIAL: 6061-T6 (SS)
- 2 FINISH: BARE
- 3 MAKE FROM: 3/8" OR 10mm THICK PLATE OR BAR

DOCUMENT REVISION HISTORY			
REV.	DESCRIPTION	DATE	APPROVED
A	INITIAL RELEASE	8 FEB 2022	A. BURKS

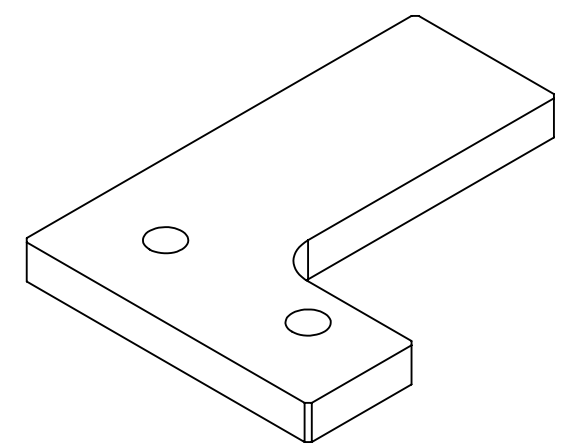
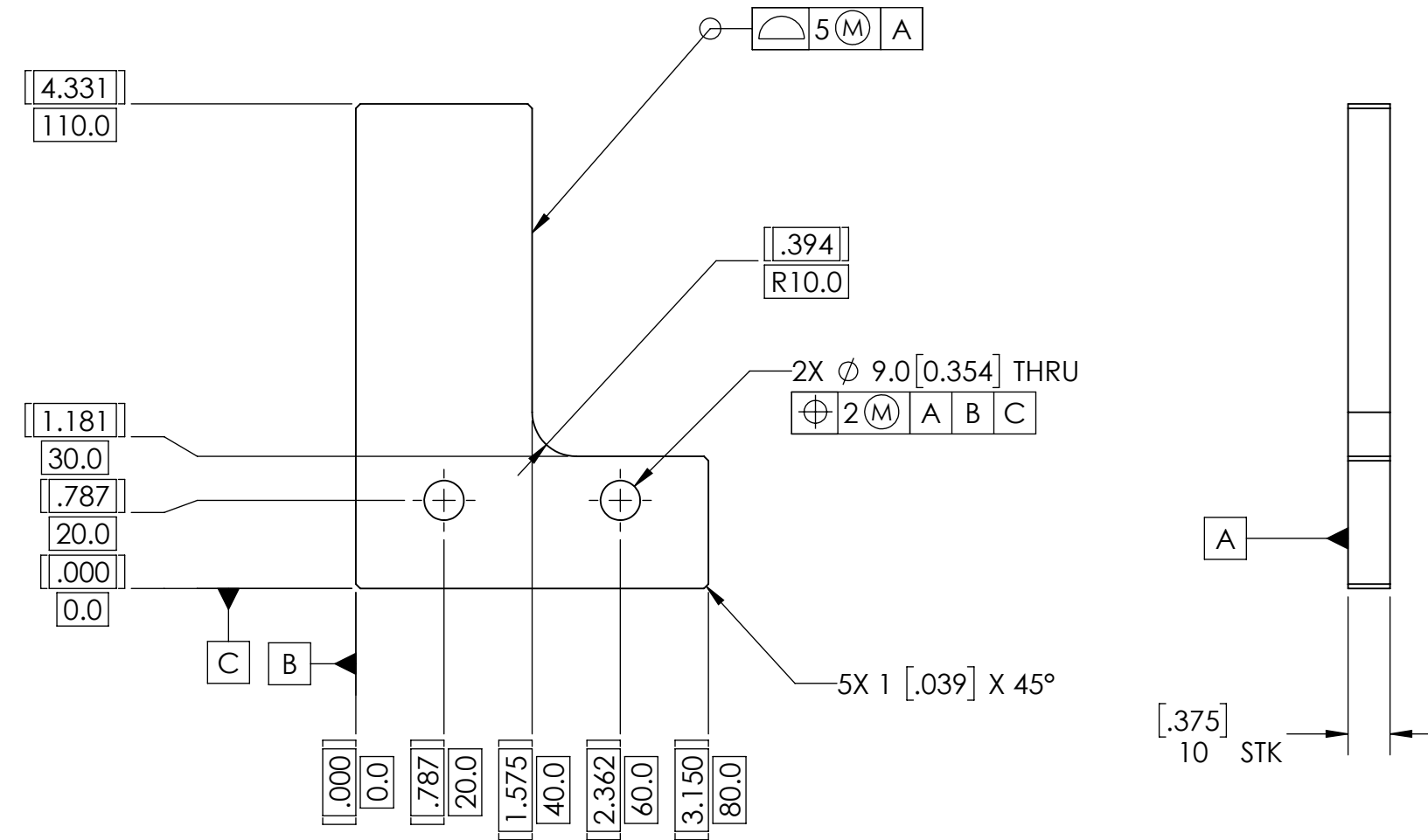

	NAME	DATE
DRAWN	A. BURKS	2/8/2022
CHECKED		
ANALYZED	A. BURKS	2/8/2022
APPROVED	A. BURKS	2/8/2022

BURKS BUILDS www.burksbuilds.com	
DRAWING TITLE HARD STOP PLATE	
DRAWING ID CNCR-SPIN-HS	REV A
DO NOT SCALE DRAWING	THIRD ANGLE
SHEET 1 OF 1	

THE DESIGN IS PROVIDED "AS IS", WITHOUT WARRANTY OF ANY KIND, EXPRESS OR IMPLIED, INCLUDING BUT NOT LIMITED TO THE WARRANTIES OF MERCHANTABILITY, FITNESS FOR A PARTICULAR PURPOSE AND NON-INFRINGEMENT. IN NO EVENT SHALL THE AUTHORS OR COPYRIGHT HOLDERS BE LIABLE FOR ANY CLAIM, DAMAGES OR OTHER LIABILITY, WHETHER IN AN ACTION OF CONTRACT, TORT OR OTHERWISE, ARISING FROM, OUT OF OR IN CONNECTION WITH THE DESIGN OR THE USE OR OTHER DEALINGS IN THE DESIGN.

UNLESS OTHERWISE SPECIFIED:
DIMENSIONS ARE IN MILLIMETERS
INTERPRET DRAWING PER ASME Y14.100
INTERPRET DIMENSIONS PER ASME Y14.5

TOLERANCES, UNLESS OTHERWISE SPECIFIED:
X ±2.0 X° ±1.0°
X.X ±0.5 X.X° ±0.2°
X.XX ±0.25

6

5

4

3

2

1

D

D

C

C

B

B

A

A